

# Mounting Kit Appendix

# Anybus<sup>®</sup>-CompactCom

Doc.Id. SCM-1200-044  
Rev. 1.13

## HMS Industrial Networks AB

---

	☎	✉
Germany	+49 - 721 - 96472 - 0	ge-sales@hms-networks.com
Japan	+81 - 45 - 478 - 5340	jp-sales@hms-networks.com
Sweden	+46 - 35 - 17 29 20	sales@hms-networks.com
U.S.A.	+1 - 312 - 829 - 0601	us-sales@hms-networks.com
France	+33 - 3 89 32 76 76	fr-sales@hms-networks.com
Italy	+39 - 347 - 00894 - 70	it-sales@hms-networks.com
China	+86 - 10 - 8532 - 3183	cn-sales@hms-networks.com





# Table of Contents

<b>Preface</b>	<b>About This Document</b>	
	How To Use This Document .....	P-1
	Important User Information .....	P-1
	Related Documents.....	P-2
	Document History .....	P-2
	Document Conventions.....	P-3
	Support .....	P-4
<b>Chapter 1</b>	<b>Anybus-CompactCom Mounting Kit</b>	
	General Information.....	1-1
	Ordering Information.....	1-1
	Proposed Footprint.....	1-2
	Host Connectors .....	1-2
	Height Restrictions.....	1-3
	Assembly.....	1-3
<b>Chapter 2</b>	<b>Measurements</b>	
	General.....	2-1
	D-sub.....	2-1
	RJ45 .....	2-2
	USB.....	2-2
	Pluggable Screw Terminal (5.08mm).....	2-3
<b>Appendix A</b>	<b>Technical Specification</b>	
	Environmental.....	A-1
	Shock and Vibration .....	A-1
	Electrical Characteristics .....	A-1
	Regulatory Compliance .....	A-2



## About This Document

### How To Use This Document

This document is intended to be used in conjunction with the Anybus-CompactCom Hardware- and Software Design Guides.

This document is intended to provide a good understanding of the mechanical and electric properties of the Anybus-CompactCom platform. It does not cover any of the network specific features offered by the various incarnations of the product; this information is instead available as separate documents (Fieldbus Appendix).

For more information, documentation etc., please visit the HMS website, 'www.anybus.com'.

### Important User Information

Anybus-CompactCom and the technology used in Anybus-CompactCom is protected by patent, pending patents, copyright and trademark laws under the United States of America and international law.

The data and illustrations found in this document are not binding. We, HMS Industrial Networks AB, reserve the right to modify our products in line with our policy of continuous product development. The information in this document is subject to change without notice and should not be considered as a commitment by HMS Industrial Networks AB. HMS Industrial Networks AB assumes no responsibility for any errors that may appear in this document.

There are many applications of this product. Those responsible for the use of this device must ensure that all the necessary steps have been taken to verify that the application meets all performance and safety requirements including any applicable laws, regulations, codes, and standards.

Anybus® is a registered trademark of HMS Industrial Networks AB. All other trademarks are the property of their respective holders. The examples and illustrations in this document are included solely for illustrative purposes. Because of the many variables and requirements associated with any particular implementation, HMS cannot assume responsibility or liability for actual use based on these examples and illustrations.

<b>Warning:</b>	This is a class A product. In a domestic environment this product may cause radio interference in which case the user may be required to take adequate measures.
-----------------	------------------------------------------------------------------------------------------------------------------------------------------------------------------

<b>ESD Note:</b>	This product contains ESD (Electrostatic Discharge) sensitive parts that may be damaged if ESD control procedures are not followed. Static control precautions are required when handling the product. Failure to observe this may cause damage to the product.
------------------	-----------------------------------------------------------------------------------------------------------------------------------------------------------------------------------------------------------------------------------------------------------------



## Document Conventions

The following conventions are used throughout this manual:

- Numbered lists provide sequential steps
- Bulleted lists provide information, not procedural steps
- The term 'Anybus' or 'module' is used when referring to the Anybus-CompactCom module.
- The terms 'host' or 'host application' is used when referring to the hardware that hosts the Anybus-CompactCom module.
- All measurements expressed in this document have a tolerance of  $\pm 0.10\text{mm}$  unless otherwise stated.

# Support

## HMS Sweden (Head Office)

E-mail: [support@hms-networks.com](mailto:support@hms-networks.com)  
Phone: +46 (0) 35 - 17 29 20  
Fax: +46 (0) 35 - 17 29 09  
Online: [www.anybus.com](http://www.anybus.com)

## HMS North America

E-mail: [us-support@hms-networks.com](mailto:us-support@hms-networks.com)  
Phone: +1-312-829-0601  
Toll Free: +1-888-8-Anybus  
Fax: +1-312-738-5873  
Online: [www.anybus.com](http://www.anybus.com)

## HMS Germany

E-mail: [ge-support@hms-networks.com](mailto:ge-support@hms-networks.com)  
Phone: +49-721-96472-0  
Fax: +49-721-964-7210  
Online: [www.anybus.com](http://www.anybus.com)

## HMS Japan

E-mail: [jp-support@hms-networks.com](mailto:jp-support@hms-networks.com)  
Phone: +81-45-478-5340  
Fax: +81-45-476-0315  
Online: [www.anybus.com](http://www.anybus.com)

## HMS China

E-mail: [cn-support@hms-networks.com](mailto:cn-support@hms-networks.com)  
Phone: +86 10 8532 3023  
Online: [www.anybus.com](http://www.anybus.com)

## HMS Italy

E-mail: [it-support@hms-networks.com](mailto:it-support@hms-networks.com)  
Phone: +39 039 59662 27  
Fax: +39 039 59662 31  
Online: [www.anybus.com](http://www.anybus.com)

## HMS France

E-mail: [mta@hms-networks.com](mailto:mta@hms-networks.com)  
Phone: +33 (0) 3 89 32 76 41  
Fax: +33 (0) 3 89 32 76 31  
Online: [www.anybus.com](http://www.anybus.com)

# Anybus-CompactCom Mounting Kit

## General Information

The Anybus-CompactCom Mounting Kit has been designed for applications where the standard Anybus-CompactCom plug-in housing concept cannot be used. This enables full Anybus-CompactCom functionality for all applications without loss of network compatibility or environmental characteristics.

The kit is easy to assemble, and is based on a few plastic parts which when assembled secures the Anybus module firmly onto the host application.

To support this concept in the host application, the PCB must be designed according to the footprint specification in this document.

To guarantee proper EMC behaviour, it is also important that the application supports the PE (protective earth) and grounding mechanisms found on all Anybus-CompactCom modules.

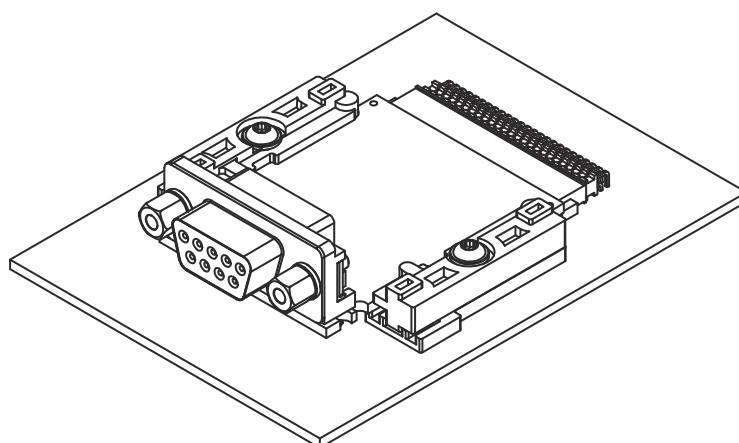
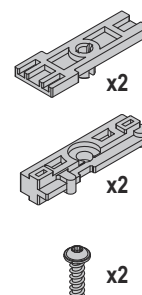

### Notes:

- All measurements expressed in this document have a tolerance of  $\pm 0.10\text{mm}$  unless stated otherwise.
- For general information about the Anybus-CompactCom platform, consult the Anybus-CompactCom Hardware- and Software Design Guides.
- The tightening torque/speed for the mounting screws must not exceed 0.40 Nm.

## Ordering Information

Part No.	Name	Contents
019180	ABCC Mounting Kit	100 x Bottom Part 100 x Top Part 100 x Screw

## Proposed Footprint

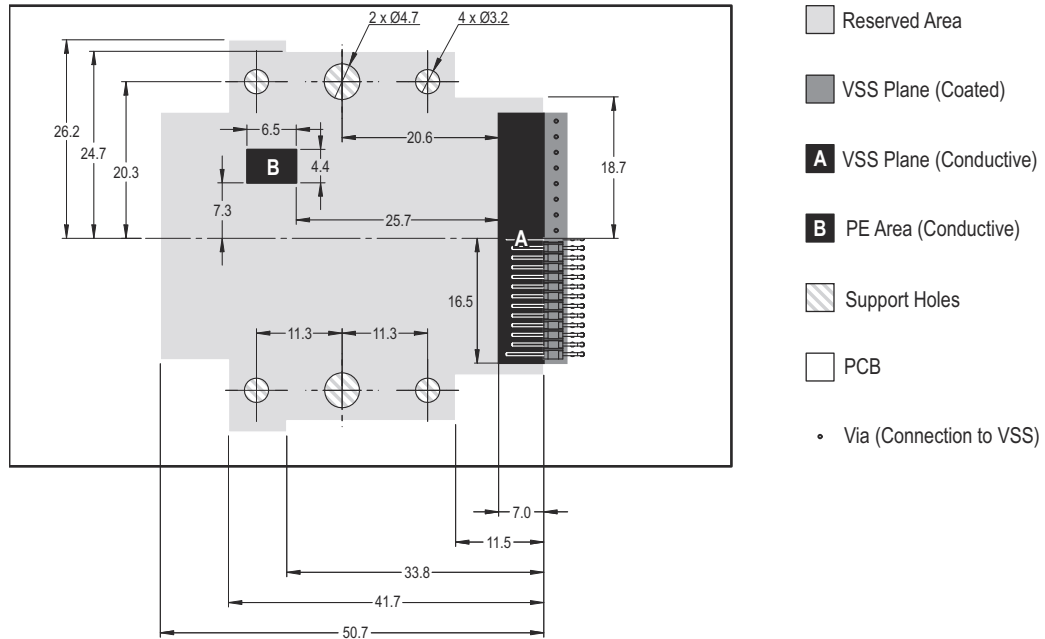

Area	Description
Reserved Area	To ensure isolation and mechanical compatibility, it is strongly advised that this area is kept completely free from components and signal lines. <u>Under no circumstances</u> may components, vias, or signal lines, be placed on the PCB-layer facing the Anybus module. Failure to comply with this requirement may induce EMC/EMI problems, mechanical compatibility issues, or even short circuit.
PE Area (Conductive)	To achieve proper EMC behaviour and to provide support for different cable shielding standards, this area must be tin plated (preferably using Hot Air Levelling technology) and have a stable, low impedance connection to protective earth.
VSS Plane (Coated)	The exact shape of this area depends on the properties of the CompactFlash connector. It is however important to follow these basic design rules:
VSS Plane (Conductive)	<ul style="list-style-type: none"> <li>- The plane must be continuous and have a stable, low impedance connection to VSS (preferably through at least 16 vias as illustrated in the figure)</li> <li>- The connection to VSS should be placed beneath the CompactFlash connector as illustrated above (see figure)</li> <li>- The plane must follow the signal path through the connector</li> <li>- The conductive part must be tin plated, preferably using Hot Air Levelling technology</li> </ul>
Support Holes	These holes are used by the mounting kit mechanics to secure the module onto the host application.
PCB	The host application PCB should be 1.6mm thick to be able to support the fastening mechanics.

## Host Connectors

The following connectors have been found to be compatible with the mounting kit.

Manufacturer	Part No.	Web
Samtec	HPT-1-25-01-L-D-RA	<a href="http://www.samtec.com">www.samtec.com</a>
3M	N7E50-D516PG-30	<a href="http://www.3m.com">www.3m.com</a>
-	-	-

## Height Restrictions

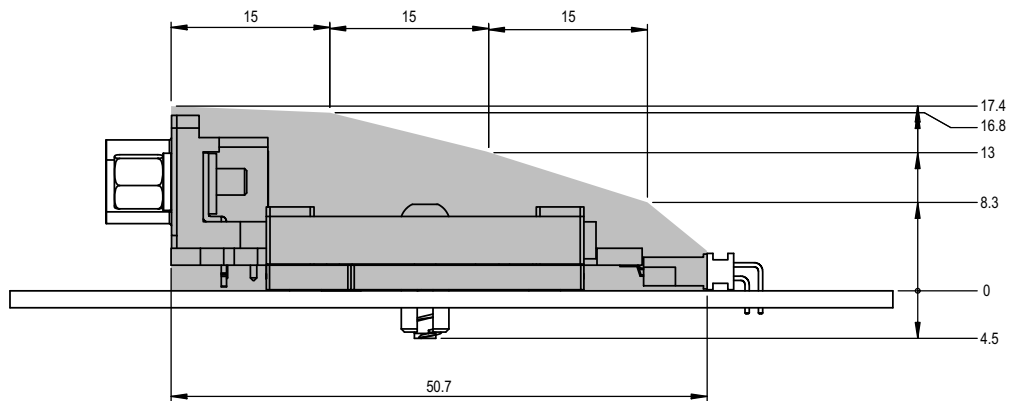

**Note:** The gray area in the figure above specifies the maximum height occupied by onboard components of the Anybus module. To ensure isolation, it is recommended to add an additional 2.5mm on top of these measurements.

## Assembly

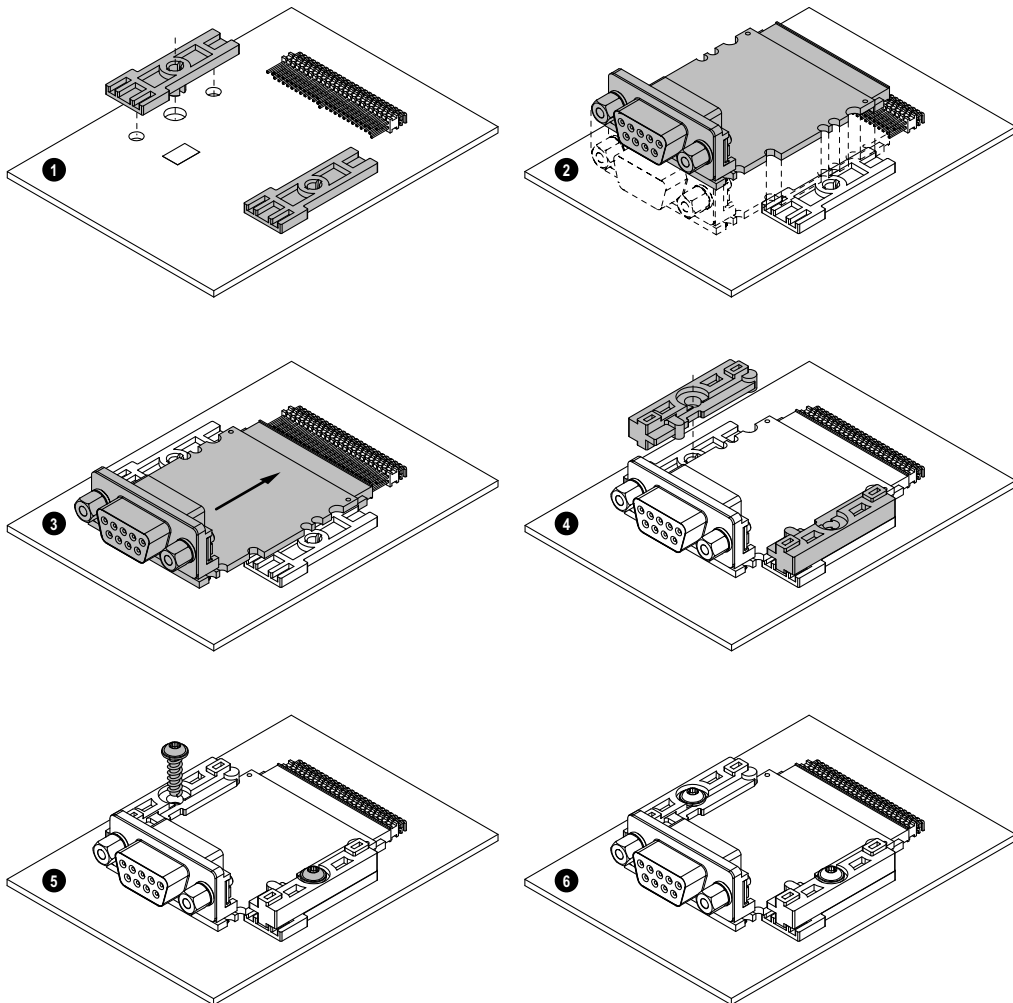

# Measurements

## General

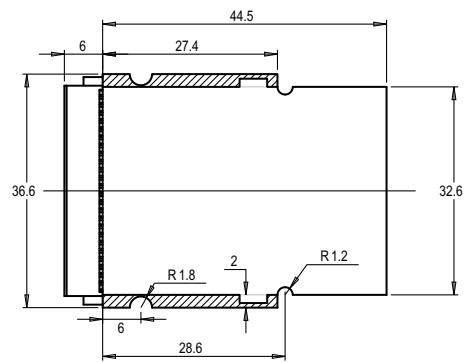
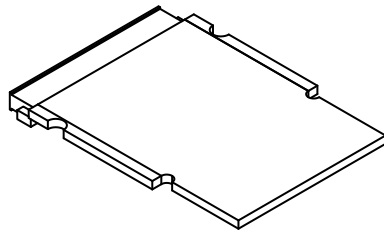
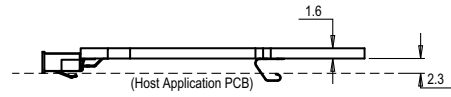

Component-free area

## D-sub

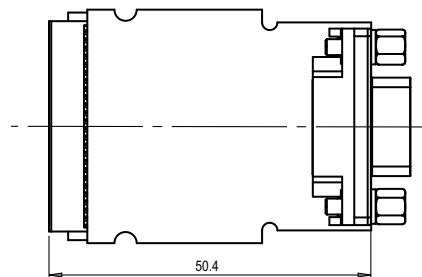
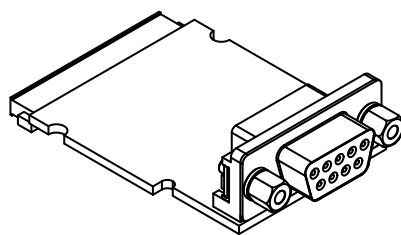
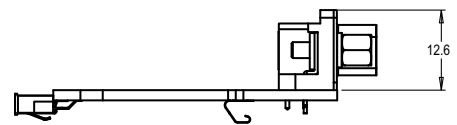
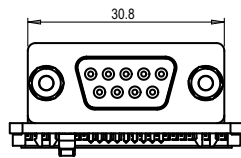

# RJ45

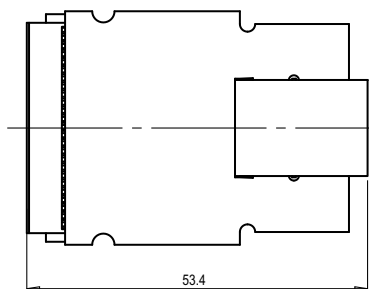
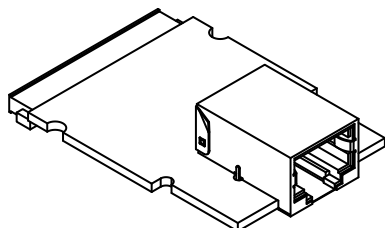
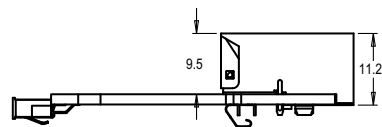
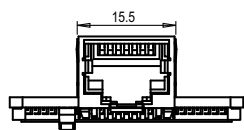

# USB

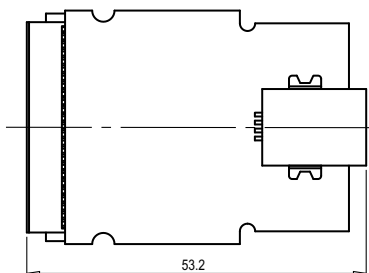
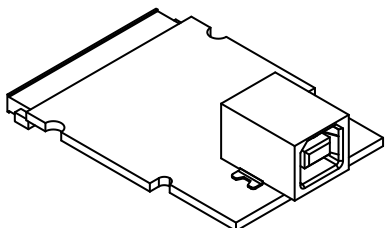
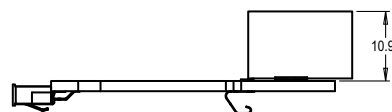
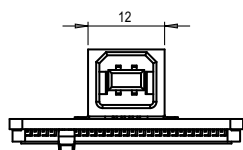

## Pluggable Screw Terminal (5.08mm)

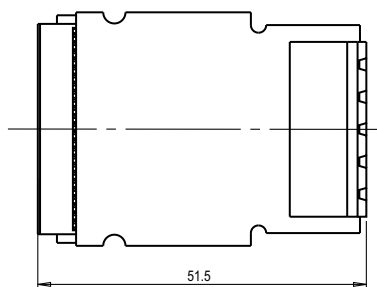
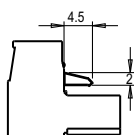
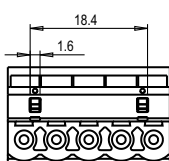
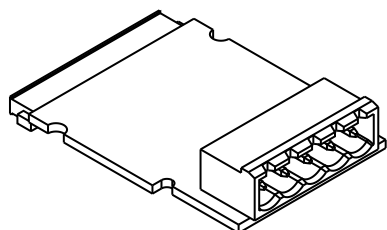
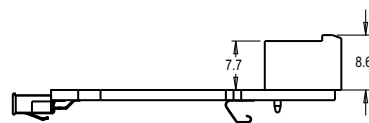
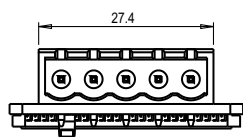

# Technical Specification

## Environmental

### Operating

Active modules: -40 to 85°C (-40 to 176°F)

Passive modules: -40 to 85°C (-40 to 176°F)

### Storage

Active modules: -40 to 85°C (-40 to 176°F)

Passive modules: -40 to 85°C (-40 to 176°F)

### Humidity

Active modules: 5 to 95% non-condensing

Passive modules: 5 to 95% non-condensing

## Shock and Vibration

### Shock (according to IEC 68-2-27)

- half-sine 30g, 11ms, 3 positive and 3 negative shocks in each of three mutually perpendicular directions
- half-sine 50g, 11ms, 3 positive and 3 negative shocks in each of three mutually perpendicular directions

### Sinusoidal vibration (according to IEC 68-2-6)

- Frequency range: 10-500Hz
- Amplitude 10-59Hz: 0.35mm
- Acceleration 50-500Hz: 5g
- Sweep rate: 1 oct/min

## Electrical Characteristics

### Operating Conditions

(Consult the general Anybus-CompactCom Hardware Design Guide for further information).

### Protective Earth & Shielding

All Anybus-CompactCom modules features a cable shield filter designed according to each network standard. To be able to support this, the host application *must* have a conductive area connected to protective earth as described in the general Anybus-CompactCom Hardware Design Guide.

HMS cannot guarantee proper EMC behaviour unless this requirement is fulfilled.

## Regulatory Compliance

### EMC Compliance (CE)

Since the Anybus-CompactCom is considered a component for embedded applications it cannot be CE-marked as an end product.

However the ABCC family is pre-compliance tested in a typical installation providing that all modules are conforming to the EMC directive in this installation.

Once our customers end product has successfully passed the EMC test using any of the ABCC modules, our pre-compliance test concept allows any other interface in the ABCC family to be embedded in that product without further EMC tests.

The EMC pre-testing has been conducted according to the following standards:

- **Emission: EN61000-6-4**
  - EN55011 Radiated emission
  - EN55011 Conducted emission
  
- **Immunity: EN61000-6-2**
  - EN61000-4-2 Electrostatic discharge
  - EN61000-4-3 Radiated immunity
  - EN61000-4-4 Fast transients/burst
  - EN61000-4-5 Surge immunity
  - EN61000-4-6 Conducted immunity

Since all ABCC modules have been evaluated according to the EMC directive through above standards, this serves as a base for our customers when certifying ABCC based products.

