



# Fieldbus Appendix

# Anybus-IC PROFIBUS

Doc.ID. SCM-1200-022  
Rev 1.56

## HMS Industrial Networks AB

---

		
Germany	+49 - 721 - 96472 - 0	ge-sales@hms-networks.com
Japan	+81 - 45 - 478 - 5340	jp-sales@hms-networks.com
Sweden	+46 - 35 - 17 29 20	sales@hms-networks.com
U.S.A.	+1 - 312 - 829 - 0601	us-sales@hms-networks.com
France	+33 - 3 89 32 76 76	fr-sales@hms-networks.com
Italy	+39 - 347 - 00894 - 70	it-sales@hms-networks.com
China	+86 - 10 - 8532 - 3183	cn-sales@hms-networks.com





# Table of Contents

<b>Preface</b>	<b>About This Document</b>	
	How To Use This Document.....	P-1
	Important User Information.....	P-1
	Related Documents.....	P-2
	Document History.....	P-2
	Conventions & Terminology.....	P-3
	Support.....	P-3
<b>Chapter 1</b>	<b>About the Anybus-IC PROFIBUS</b>	
	General.....	1-1
	Features.....	1-1
	Fieldbus Conformance Notes.....	1-1
<b>Chapter 2</b>	<b>Basic Operation</b>	
	General Information.....	2-1
	Identity Information.....	2-1
	Data Exchange.....	2-1
	Communication Settings.....	2-2
	<i>Baud rate</i> .....	2-2
	<i>Node Address</i> .....	2-2
	Fieldbus Specific Input/Output Registers.....	2-3
	<i>Switches (Fieldbus Specific Input)</i> .....	2-3
	<i>Status Indicators (Fieldbus Specific Output)</i> .....	2-3
	PROFIBUS Implementation.....	2-4
	<i>Global Control</i> .....	2-4
	<i>User Parametrization Data</i> .....	2-4
	<i>Extended Diagnostics</i> .....	2-5
	<i>Configuration Data</i> .....	2-5
	Fieldbus Fault Action.....	2-6
	<i>Bus off-line</i> .....	2-6
	<i>Bus in Clear mode</i> .....	2-6
<b>Chapter 3</b>	<b>General Parameters</b>	
	<i>SCI Rate Config (#14)</i> .....	3-1

**Chapter 4 Fieldbus Interface**

General Considerations .....	4-1
Typical Implementation.....	4-2
DB9F Pinout.....	4-2
Termination Example.....	4-3

**Chapter 5 Fieldbus Specific Parameters**

<i>FB Status (Parameter #100)</i> .....	5-2
<i>FB Init (Parameter #101)</i> .....	5-3
<i>FB Password (Parameter #102)</i> .....	5-4
<i>FB Node Address Config (Parameter #103)</i> .....	5-4
<i>FB Node Address SSC (Parameter #104)</i> .....	5-5
<i>FB Node Address Actual (Parameter #105)</i> .....	5-5
<i>PROFIBUS Baud Rate Actual (Parameter #106)</i> .....	5-6
<i>PROFIBUS ID Number Config (Parameter #107)</i> .....	5-6
<i>PROFIBUS ID Number Actual (Parameter #108)</i> .....	5-7
<i>Default Config Data Length (Parameter #109)</i> .....	5-7
<i>Config Data Length (Parameter #110)</i> .....	5-7
<i>User Parametrization Data Length (Parameter #111)</i> .....	5-8
<i>Extended Diagnostic Length (Parameter #112)</i> .....	5-8
<i>SSA Enable (Parameter #113)</i> .....	5-9
<i>SSA Node Address (Parameter #114)</i> .....	5-9
<i>Default Config Data (Parameter #115)</i> .....	5-10
<i>Config Data (Parameter #116)</i> .....	5-10
<i>User Parametrization Data (Parameter #117)</i> .....	5-10
<i>Extended Diagnostics (Parameter #118)</i> .....	5-11
<i>Firmware Revision (Parameter #119)</i> .....	5-12
<i>Serial Number (Parameter #120)</i> .....	5-12

**Chapter 6 Fieldbus Specific Initialization**

General Information .....	6-1
Initialization State Machine.....	6-1
<i>STATE 1 (Initial state)</i> .....	6-2
<i>STATE 2</i> .....	6-2
<i>STATE 3</i> .....	6-2

**Appendix A Technical Specification**

Electrical Specification.....	A-1
<i>Protective Earth (PE) Requirements</i> .....	A-1
<i>Power Supply</i> .....	A-1
Environmental Specification .....	A-1
EMC Compliance (CE) .....	A-1

## About This Document

## How To Use This Document

This document is intended to be used as a supplement to the Anybus-IC Design Guide. The reader of this document is expected to have basic knowledge in the PROFIBUS fieldbus system, and communication systems in general.

Please consult the general Anybus-IC Design Guide for further information about the Anybus-IC platform.

## Important User Information

The data and illustrations found in this document are not binding. We, HMS Industrial Networks AB, reserve the right to modify our products in line with our policy of continuous product development. The information in this document is subject to change without notice and should not be considered as a commitment by HMS Industrial Networks AB. HMS Industrial Networks AB assumes no responsibility for any errors that may appear in this document.

There are many applications of this product. Those responsible for the use of this device must ensure that all the necessary steps have been taken to verify that the application meets all performance and safety requirements including any applicable laws, regulations, codes, and standards.

Anybus® is a registered trademark of HMS Industrial Networks AB. All other trademarks are the property of their respective holders.

The examples and illustrations in this document are included solely for illustrative purposes. Because of the many variables and requirements associated with any particular implementation, HMS Industrial Networks cannot assume responsibility or liability for actual use based on these examples and illustrations.

<b>Warning:</b>	This is a class A product. In a domestic environment this product may cause radio interference in which case the user may be required to take adequate measures.
-----------------	--

<b>ESD Note:</b>	This product contains ESD (Electrostatic Discharge) sensitive parts that may be damaged if ESD control procedures are not followed. Static control precautions are required when handling the product. Failure to observe this may cause damage to the product.
------------------	---

## Related Documents

Document name	Author
Anybus-IC Design Guide	HMS
Digital Communications IEC61158 Type 3 (PROFIBUS)	IEC

## Document History

### Summary of Recent Changes (v1.55... v1.56)

Change	Page(s)
Removed empty cross-references to Set_Slave_Address	5-9
Added information on User Parametrization Data	2-4
Added parameter SCI Rate Config	3-1

### Revision List

Revision	Date	Author(s)	Chapter(s)	Description
<=1.33	-	-	-	(see previous releases)
1.50	2007-01-09	PeP	-	Major rewrite
1.52	2007-05-28	PeP	A	Corrected power consumption
1.53	2007-06-19	PeP	4	Corrected figure (bias resistor wiring)
1.54	2007-12-14	PeP	5-12	Minor update
1.55	2008-11-07	HeS	P, A	Minor update
1.56	2009-10-02	KeL	2, 3, 5	Minor update

## Conventions & Terminology

The following conventions are used throughout this document:

- Numbered lists provide sequential steps
- Bulleted lists provide information, not procedural steps
- The term ‘module’ is refers to the Anybus module
- The term ‘application’ refers to the device connected to the Anybus application connector
- Hexadecimal values are written in the format NNNNh, where NNNN is the hexadecimal value.
- Binary values are written in the format NNNNb, where NNNN is the binary value.
- 16/32 bit values are written in big endian Motorola format
- Floating point values are in the IEEE Standard 754 format

## Support

### HMS Sweden (Head Office)

E-mail:	<a href="mailto:support@hms-networks.com">support@hms-networks.com</a>
Phone:	+46 (0) 35 - 17 29 20
Fax:	+46 (0) 35 - 17 29 09
Online:	<a href="http://www.anybus.com">www.anybus.com</a>

### HMS North America

E-mail:	<a href="mailto:us-support@hms-networks.com">us-support@hms-networks.com</a>
Phone:	+1-312-829-0601
Toll Free:	+1-888-8-Anybus
Fax:	+1-312-738-5873
Online:	<a href="http://www.anybus.com">www.anybus.com</a>

### HMS Germany

E-mail:	<a href="mailto:ge-support@hms-networks.com">ge-support@hms-networks.com</a>
Phone:	+49-721-96472-0
Fax:	+49-721-964-7210
Online:	<a href="http://www.anybus.com">www.anybus.com</a>

### HMS Japan

E-mail:	<a href="mailto:jp-support@hms-networks.com">jp-support@hms-networks.com</a>
Phone:	+81-45-478-5340
Fax:	+81-45-476-0315
Online:	<a href="http://www.anybus.com">www.anybus.com</a>

### HMS China

E-mail:	<a href="mailto:cn-support@hms-networks.com">cn-support@hms-networks.com</a>
Phone:	+86 10 8532 3023
Online:	<a href="http://www.anybus.com">www.anybus.com</a>

### **HMS Italy**

E-mail: [it-support@hms-networks.com](mailto:it-support@hms-networks.com)  
Phone: +39 039 59662 27  
Fax: +39 039 59662 31  
Online: [www.anybus.com](http://www.anybus.com)

### **HMS France**

E-mail: [mta@hms-networks.com](mailto:mta@hms-networks.com)  
Phone: +33 (0) 3 89 32 76 41  
Fax: +33 (0) 3 89 32 76 31  
Online: [www.anybus.com](http://www.anybus.com)

# About the Anybus-IC PROFIBUS

## General

The Anybus-IC PROFIBUS communication module provides instant PROFIBUS slave connectivity through the generic Anybus-IC application interface. Any device that supports this standard can take advantage of the features provided by the module, allowing seamless network integration regardless of network type.

## Features

- Galvanically isolated bus electronics
- Up to 144 bytes of fieldbus I/O in each direction
- Automatically detects the PROFIBUS baud rate
- User Parametrization Data support
- Extended diagnostic support
- Set Slave Address support
- Device identity customization
- Generic GSD-file provided

## Fieldbus Conformance Notes

The module is pre-certified for network compliance under the following conditions:

- Parameters are set to their default values, or to values which does not contradict the settings specified in the generic GSD-file supplied by HMS
- The fieldbus connector must contain at least the following signals:  
A-Line, B-Line, RTS, Shield, GND\_BUS

Any deviations from what is stated above will require changes in the GSD-file and thus also re-certification of the end product. For further information, please contact HMS.

# Basic Operation

## General Information

### Software Requirements

Generally, no network-specific support code needs to be written in order to support the Anybus-IC PROFIBUS. However, due to natural reasons, advanced fieldbus-specific features may require the use of PROFIBUS-specific parameters.

For general information about the Anybus-IC software interface, consult the Anybus-IC Design Guide.

See also...

- 5-1 “Fieldbus Specific Parameters”

### GSD-files

On PROFIBUS, the characteristics of a device is stored in an ASCII data file with the suffix ‘GSD’. This file is used by the PROFIBUS configuration tool when setting up the network.

HMS provides a generic GSD-file, which corresponds to the default settings in the module. However, due to the flexible nature of the Anybus concept, it is possible to alter the behaviour of the product in ways that invalidates the generic GSD-file.

See also...

- 1-1 “Fieldbus Conformance Notes”

## Identity Information

On the PROFIBUS network, the module identifies itself as follows:

Information	Default Value	Comments
Vendor Name	'HMS Industrial Networks'	-
Model Name	'Anybus-IC PROFIBUS'	-
Ident Number	1810h	Can be customized.
Manufacturer ID	010Ch (HMS)	-
Order ID	'ABIC-PDP'	-

See also...

- 5-6 “PROFIBUS ID Number Config (Parameter #107)”
- 5-7 “PROFIBUS ID Number Actual (Parameter #108)”

## Data Exchange

The module supports up to 144 bytes of fieldbus I/O in each direction.

All fieldbus I/O data is exchanged as Cyclical I/O on PROFIBUS.

# Communication Settings

## Baudrate

The Anybus module detects the PROFIBUS baudrate automatically.

Supported baudrates:

9.6 kbps	187.5 kbps	6 Mbps
19.2 kbps	500 kbps	12 Mbps
45.45 kbps	1.5 Mbps	
93.75 kbps	3 Mbps	

See also...

- 5-6 “PROFIBUS Baud Rate Actual (Parameter #106)”

## Node Address

The module supports BCD-coded switches (range 0... 99) as well as binary switches (range 0... 126). The node address can also be set via the SCI-interface.

The module supports the Set Slave Address (SSA) functionality, which allows a master or a configuration tool to change the node address of the module. This feature is supported by the generic .GSD-file, and is enabled when any of the following conditions are true:

- Node address source<sup>1</sup> value equals 126
- The ‘FBNA’-bit in parameter #8 (‘Configuration Bits’) is set.

The figure on the right illustrates how the node address is established when using this feature.

This functionality is enabled by default, but can optionally be completely disabled using parameter #113 ‘SSA Enabled’ (note however that this invalidates the generic .GSD-file).

See also...

- Anybus-IC Design Guide (Parameter #8 ‘Configuration Bits’)
- 1-1 “Fieldbus Conformance Notes”
- 2-3 “Fieldbus Specific Input/Output Registers”
- 5-4 “FB Node Address Config (Parameter #103)”
- 5-5 “FB Node Address SSC (Parameter #104)”
- 5-5 “FB Node Address Actual (Parameter #105)”
- 5-9 “SSA Enable (Parameter #113)”
- 5-9 “SSA Node Address (Parameter #114)”

**Note:** The SSA-functionality requires firmware revision 1.14 or higher.

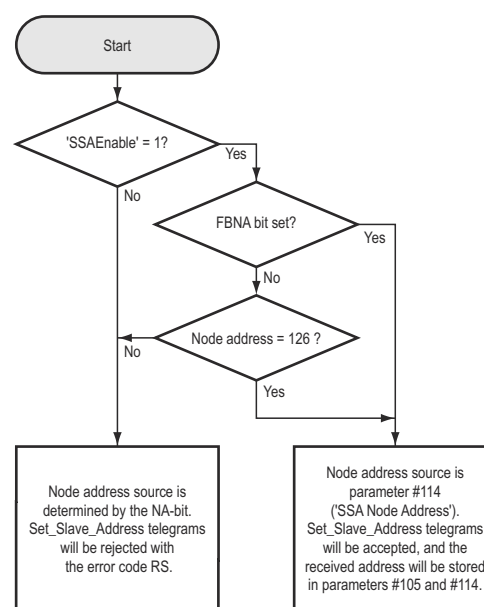

1. The node address source is specified by the ‘NA’-bit in parameter #8 (‘Configuration Bits’)

## Fieldbus Specific Input/Output Registers

### Switches (Fieldbus Specific Input)

The Fieldbus Specific Input is used for fieldbus-specific configuration settings and supports two types of switches/coding.

- **BCD-coded Switches**

This type of switches allows the PROFIBUS node address to be set in the range 0... 99.

- **Binary Switches**

This type of switches allows the node address to be set in the range 0... 126 as follows:

b7	b6	b5	b4	b3	b2	b1	b0	Node Address
-	0	0	0	0	0	0	0	0
-	0	0	0	0	0	0	1	1
-	0	0	0	0	0	1	0	2
-	0	0	0	0	0	1	1	3
...	...	...	...	...	...	...	...	...
-	1	1	1	1	1	0	1	125
-	1	1	1	1	1	1	0	126 (reserved for SSA)
-	1	1	1	1	1	1	1	(invalid on PROFIBUS)

**Note:** Bit 7 is ignored on PROFIBUS.

**Note:** The type of switch used is specified in parameter #9 ("Switch Coding"). On PROFIBUS, the default value for this parameter is 00h (BCD Switches). However, since this is fieldbus dependant, there is no guarantee that the same type of switch is used by default on other networks.

See also...

- Anybus-IC Design Guide (parameter #9 "Switch Coding")
- 2-2 "Communication Settings"

### Status Indicators (Fieldbus Specific Output)

The Fieldbus Specific Output is used for fieldbus-specific status indications as follows:

Bit	State	Colour	Description
0	Clear (0)	Off	Node Off-Line or Power not supplied
	Set (1)	Green	Node in Data Exchange Mode
	Toggling (1Hz)	Green, flashing	Node in Clear Mode
1	Clear (0)	Off	No Error or Power not supplied
	Set (1)	Red	Error in initialization of PROFIBUS ASIC
	Toggling (1Hz)	Red, flashing	Error in configuration data and/or User Parametrization Data
2... 7	-	-	(not used on PROFIBUS)

See also...

- Anybus-IC Design Guide (parameter #7 "LED State")

# PROFIBUS Implementation

## Global Control

The Anybus module supports the following global commands:

- **FREEZE/UNFREEZE of inputs**  
Works according to the PROFIBUS DP specification
- **SYNC/UNSYNC of outputs**  
Works according to the PROFIBUS DP specification
- **CLEAR**  
See 2-6 “Bus in Clear mode”.

See also...

- 5-3 “FB Init (Parameter #101)”
- 6-1 “Fieldbus Specific Initialisation”

## User Parametrization Data

The master identifies itself with the slaves by sending Parametrization Data, specifying how the slave shall operate (i.e. Master address, PNO-ID, Sync/Freeze capabilities etc.).

The Parametrization Data consists of two parts:

	DP Standard Parameters	User Parametrization Data
<b>Size</b>	7 bytes	Dynamic (up to 237 bytes, first byte reserved for Anybus)
<b>Defined by</b>	IEC 61158-6	Application
<b>Evaluated by</b>	Anybus	Anybus - <i>or</i> - Application
<b>Supported by the Generic GSD-file</b>	Yes	No

As seen in the table above, support for additional (i.e. > 1 byte) User Parametrization Data can optionally be implemented by supporting the corresponding parameters in the application. Note however that this invalidates the generic GSD-file supplied by HMS.

If enabled, the User Parametrization Data has to be acknowledged by the application.

See also...

- 1-1 “Fieldbus Conformance Notes”
- 2-1 “Identity Information”
- 5-3 “FB Init (Parameter #101)”
- 5-8 “User Parametrization Data Length (Parameter #111)”
- 5-10 “User Parametrization Data (Parameter #117)”

## Extended Diagnostics

In addition to the 6 mandatory Diagnostic Data bytes, the module supports up to 200 bytes of Extended Diagnostic data. This data can be used e.g. to notify the PROFIBUS master of a fault that has occurred in the application.

The PROFIBUS specification specifies three different types of Extended Diagnostic data:

- Device related
- Identifier related
- Channel related

The application is responsible for setting up the correct diagnostics prior to sending it to the master. Consult the PROFIBUS specification for further information about the different diagnostic settings.

Extended Diagnostics is not supported by default, but can optionally be supported by implementing support for the corresponding parameters in the application. Note however that this invalidates the generic GSD-file supplied by HMS.

See also...

- 1-1 “Fieldbus Conformance Notes”
- 2-1 “Identity Information”
- 5-3 “FB Init (Parameter #101)”
- 5-8 “Extended Diagnostic Length (Parameter #112)”
- 5-11 “Extended Diagnostics (Parameter #118)”

## Configuration Data

The Anybus module is a modular slave, which means that the input/output block size is flexible and not tied to a specific block length. The input/output blocks are specified by so-called Identifier bytes, which defines the Input- and/or Output Data length as well as data consistency. The Identifier bytes are defined in the GSD-file and are automatically extracted by the configuration tool when adding modules to the configuration.

During network startup, the master sends its Actual Configuration to the Anybus module for validation. By default, the Anybus module adopts its Configuration Data from the master (i.e. a mismatch is not possible, unless the configuration is bigger than the data sizes specified during initialization).

Optionally, the Configuration Data can be acknowledged by the application (Fieldbus-Specific Mode).

See also...

- 1-1 “Fieldbus Conformance Notes”
- 2-1 “Identity Information”
- 5-3 “FB Init (Parameter #101)”
- 5-7 “Default Config Data Length (Parameter #109)”
- 5-7 “Config Data Length (Parameter #110)”
- 5-10 “Default Config Data (Parameter #115)”
- 5-10 “Config Data (Parameter #116)”

## Fieldbus Fault Action

### Bus off-line

When the fieldbus is off-line, the outputs can behave in different ways depending of the setting of parameter #10 (“Offline Action”).

See also...

- Anybus-IC Design Guide, parameter #10 (“Offline Action”)

### Bus in Clear mode

When the fieldbus master issues the Global Control telegram ‘Clear’, the outputs can behave in different ways depending of the setting of parameter #11 (“Idle Action”).

Note that input data can be read by the master even if the module is in ‘Clear’-mode.

See also...

- Anybus-IC Design Guide, parameter #11 (“Idle Action”)
- 2-4 “Global Control”

---

## General Parameters

The Anybus IC modules have several parameters that are common to all versions of the module, see “Anybus IC Design Guide” for further information. Additions to these parameters are shown below.

### SCI Rate Config (#14)

This parameter is used to configure the baud rate of the SCI channel. A reset/power-cycle of the module is necessary in order for any changes to have effect.

<b>Parameter number</b>	14
<b>Modbus Address</b>	0x500E
<b>Default value</b>	0x00
<b>Range</b>	0x00h - 0x0A
<b>Size</b>	1 byte
<b>Stored in NV RAM</b>	Yes
<b>Access</b>	R/W

- **Values**

0x00 - Automatic baud rate detection (default).

0x01 - 4,8 kbit/s

0x02 - 9,6 kbit/s

0x03 - 19,2 kbit/s

0x04 - 38,4 kbit/s

0x05 - 57,6 kbit/s

0x06 - (reserved).

0x07 - 156,25 kbit/s<sup>1</sup>

0x08 - 208,333 kbit/s<sup>1</sup>

0x09 - 312,5 kbit/s<sup>1</sup>

0x0A - 625 kbit/s<sup>1</sup>

---

1. This baud rate is not supported if automatic baud rate detection is used

# Fieldbus Interface

## General Considerations

Make sure to keep the length of the stub-lines (i.e. the distance between the PROFIBUS connector and the Anybus module) as short as possible. If these stub-lines are too long, communication problems may arise when operating at higher bus speeds ( $\geq 1.5\text{Mbps}$ ). According to the PROFIBUS Test Specification, the max. allowed total length of all stub lines on a bus segment is  $80\text{cm}@12\text{Mbps}$ . Over a full bus segment of 32 nodes, this equals 25mm.

The recommended connector for PROFIBUS is a 9-pin female DSUB-connector (DB9F). Other connectors are also permitted, as long as all mandatory signals are present.

+5V BUS and GND BUS are normally used for bus termination, and may be used to power external devices such as e.g. optical transceivers (RS485 to fibre optics). In any case, such devices may not consume more than 100mA of current. Also note that these power outputs are not short circuit protected.

**Note:** Due to the individual requirements (i.e. differences in cable shield filters, max. stub-line length etc.) for each networking system, special care has to be taken if compatibility with several networking systems is required. It is therefore generally recommended to also study the design examples in the fieldbus appendices for Anybus-IC DeviceNet and Anybus-IC Ethernet/IT/IP.

See also...

- 1-1 “Fieldbus Conformance Notes”
- 4-2 “DB9F Pinout”

---

**IMPORTANT:** *The recommendations regarding PE and cable shield filters etc. has been changed slightly compared to that of older revisions of this document. The module is however fully backwards compatible with the old recommendations.*

## Typical Implementation

PROFIBUS requires a cable shield filter as shown below. If multiple networks are to be supported using the same application PCB, this has to be accounted for when routing the board, since other networking systems may use a different shielding approach.

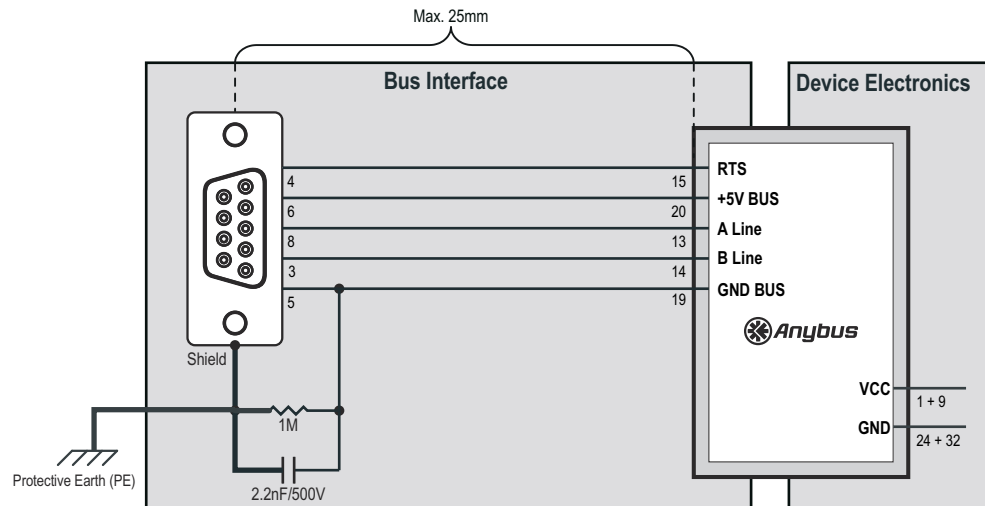

**Note:** To ensure proper EMC behaviour, the metal housing DB9F-connector must be connected to Protective Earth (PE) as illustrated above.

## DB9F Pinout

When using a DB9F connector, A-Line, B-Line, +5V BUS, GND BUS and Shield are mandatory. When using other connectors, only A-Line, B-Line and Shield are required.

PROFIBUS Connector (DB9F)		Anybus	
Pin	Signal	Pin	Signal
1	-	-	-
2	-	-	-
3	B-Line	14	FB2
4	RTS	15	FB3
5	GND BUS (isolated)	19	FB5
6	+5V BUS (output, isolated, 100mA max.)	20	FB6
7	-	-	-
8	A-Line	13	FB1
9	-	-	-
Housing <sup>a</sup>	Shield	-	-

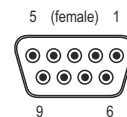

a. See 4-2 "Typical Implementation" and 4-3 "Termination Example"

See also...

- 1-1 "Fieldbus Conformance Notes"

## Termination Example

It is generally recommended to use PROFIBUS connectors with built-in termination. If this is not possible, termination can be implemented on-board as illustrated below.

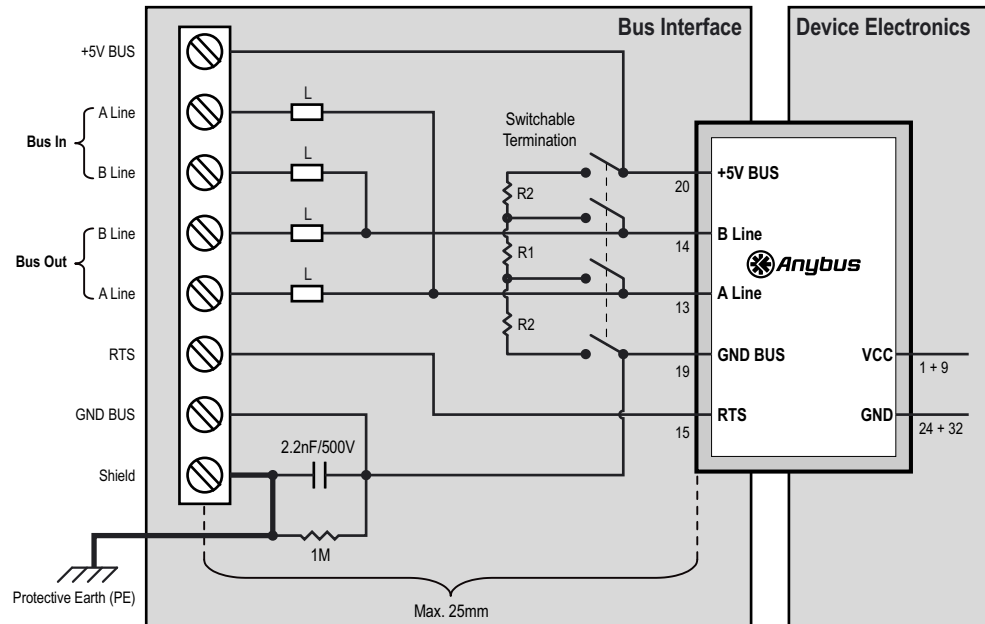

Ref.	Description
R1	220R $\pm$ 5%
R2	390R $\pm$ 5%
L	110nH $\pm$ 20%

## Fieldbus Specific Parameters

To be able to use the full functionality of every fieldbus, the Fieldbus Specific Parameters are used. These parameters are specific to the actual fieldbus used and must be configured accordingly.

The table below shows an overview of the parameters.

#	R/W	Name	Size	Default value	Modbus Address
100	R	FB Status	2 bytes	-	7000h
101	R/W	FB Init	1 byte	00h	7001h
102	W	FB Password	2 bytes	-	7002h
103	R/W	FB Node Address Config	1 byte	7Eh	7003h
104	R	FB Node Address SSC	1 byte	-	7004h
105	R	FB Node Address Actual	1 byte	-	7005h
106	R	PROFIBUS baud rate Actual	1 byte	-	7006h
107	R/(W)	PROFIBUS ID Number Config	2 bytes	1810h	7007h
108	R	PROFIBUS ID Number Actual	2 bytes	-	7008h
109	R/W	Default Config Data Length	1 byte	-	7009h
110	R	Config Data Length	1 byte	-	700Ah
111	R	User Parametrization Data Length	2 bytes	-	700Bh
112	R/W	Extended Diagnostic Length	1 byte	00h	700Ch
113	R/W	SSA Enable	1 byte	01h (enabled)	700Dh
114	R	SSA Node Address	1 byte	7Eh	700Eh
115	R/W	Default Config Data	24 bytes	00h	700Fh - 701Ah
116	R	Config Data	24 bytes	-	701Bh - 7026h
117	R	User Parametrization Data	237 bytes	-	7027h - 709Dh
118	R/W	Extended Diagnostics	202 bytes	00h	709Eh - 7102h
119	R(W)	Firmware Revision	2 bytes	-	7103h
120	R(W)	Serial Number	4 bytes	-	7104h

**Note:** Byte sized parameter values are placed in the least significant byte of the word.

## FB Status (Parameter #100)

This parameter holds information about the current fieldbus status.

Parameter Name	'FB Status'
Parameter Number	100
Modbus Address	7000h
Default Value	-
Range	0000h - FFFFh
Size	2 bytes
Stored in NV RAM	No
Access	R

### Bit layout

b15	b14	b13	b12	b11	b10	b9	b8	b7	b6	b5	b4	b3	b2	b1	b0
-	-	-	-	-	-	IDLE	BUS	-	-	-	-	-	-	CFG	PRM

- **PRM<sup>1</sup>**

This bit indicates if a Set\_Prm telegram has been received from the PROFIBUS master.

- 1: Set\_Prm telegram has been received from the PROFIBUS master. The application should check the received User Parametrization Data in parameter #117 ("User Parametrization Data") and respond by setting/clearing bit 0 of parameter #101 ("FB Init").
- 0: Set\_Prm telegram has not been received from the PROFIBUS master.

- **CFG<sup>1</sup>**

This bit indicates if a Chk\_cfg telegram has been received from the PROFIBUS master.

- 1: Chk\_Cfg telegram has been received from the PROFIBUS master. The application should check the received Configuration Data in parameter #116 ("Config Data") and respond by setting/clearing bit 1 of parameter #101 ("FB Init").
- 0: Chk\_Cfg telegram is not received from the PROFIBUS master.

- **BUS**

- 1: Node is on line
- 0: Node is off line

- **IDLE**

- 1: Node is in Clear mode
- 0: Node is not in Clear mode

---

1. These bits are only valid when using the Fieldbus Specific Initialization option. For more information, see 6-1 "Fieldbus Specific Initialisation".

## FB Init (Parameter #101)

This parameter is used to acknowledge User Parametrization Data and Configuration Data received from the PROFIBUS master when using the Fieldbus Specific Initialization option. For more information, see 6-1 “Fieldbus Specific Initialisation”.

Parameter Name	'FB Init'
Parameter Number	101
Modbus Address	7001h
Default Value	00h
Range	00h - FFh
Size	1 byte
Stored in NV RAM	No
Access	R/W

### Bit layout

b7	b6	b5	b4	b3	b2	b1	b0
-	-	-	-	-	-	CFG	PRM

- **PRM<sup>1</sup>**

This bit is used to accept / reject the User Configuration data found in parameter #117 (“User Parametrization Data”) when the module has received a Set\_Prm telegram from the PROFIBUS master.

The application should set this bit accordingly after checking the received Parametrization Data.

**1:** Accept User Parametrization Data

**0:** Reject User Parametrization Data

- **CFG<sup>1</sup>**

This bit is used to accept / reject the Configuration Data found in parameter #116 (“Config Data”) when the module has received a Chk\_Cfg telegram from the PROFIBUS master.

The application should set this bit accordingly after checking the received configuration.

**1:** Accept Configuration Data

**0:** Reject Configuration Data

---

1. These bits are only valid when using the Fieldbus Specific Initialization option. For more information, see 6-1 “Fieldbus Specific Initialisation”.

## FB Password (Parameter #102)

This parameter grants write access to the following parameter provided that a valid password is supplied:

- 5-6 “PROFIBUS ID Number Config (Parameter #107)”
- 5-12 “Firmware Revision (Parameter #119)”
- 5-12 “Serial Number (Parameter #120)”

(The password can be obtained by contacting HMS)

Parameter Name	'FB Password'
Parameter Number	102
Modbus Address	7002h
Default Value	-
Range	0000h - FFFFh
Size	2 bytes
Stored in NV RAM	No
Access	W

## FB Node Address Config (Parameter #103)

This parameter holds the manually configured PROFIBUS node address. Note that in order for this value to be valid, bit 4 of parameter #8 (“Configuration Bits”) must be set. Valid node address settings range from 0 to 126.

**Note:** This parameter is read once during startup, i.e. any changes requires a reset in order to have effect.

Parameter Name	'FB Address Cfg'
Parameter Number	103
Modbus Address	7003h
Default Value	7Eh
Range	00h - 7Eh
Size	1 byte
Stored in NV RAM	Yes
Access	R/W

## FB Node Address SSC (Parameter #104)

This parameter holds the auto configured fieldbus node address from the SSC interface. Note that in order for this value to be valid, bit 4 of parameter #8 (“Configuration Bits”) must be cleared.

If the SSC node address is larger than allowed by the fieldbus, the default value of parameter #103 (“FB Node Address Config”) will be used as the actual node address.

**Note:** This parameter is read once during startup, i.e. any changes requires a reset in order to have effect.

Parameter Name	'FB Address SSC'
Parameter Number	104
Modbus Address	7004h
Default Value	-
Range	00h - FFh
Size	1 byte
Stored in NV RAM	No
Access	R

## FB Node Address Actual (Parameter #105)

After initialization, this parameter holds the actual fieldbus node address. Prior to module initialization, the value of this parameter is not defined.

Parameter Name	'FB Address Act'
Parameter Number	105
Modbus Address	7005h
Default Value	-
Range	00h - 7Eh
Size	1 byte
Stored in NV RAM	No
Access	R

## PROFIBUS Baud Rate Actual (Parameter #106)

This parameter holds the actual fieldbus baud rate after the Anybus-IC is on-line. Before the Anybus-IC is on-line, the value of this parameter is not defined.

Parameter Name	'FB Baud Rate'
Parameter Number	106
Modbus Address	7006h
Default Value	-
Range	00h - 09h
Size	1 byte
Stored in NV RAM	No
Access	R

- **Value**

00h: 12Mbps	05h: 187,5kbps
01h: 6Mbps	06h: 93,75kbps
02h: 3Mbps	07h: 45,45kbps
03h: 1,5Mbps	08h: 19,2kbps
04h: 500kbps	09h: 9,6kbps

## PROFIBUS ID Number Config (Parameter #107)

This parameter holds the configured PROFIBUS ID number for the Anybus-IC. The “set default” command in parameter #1 (“Module mode”) does not affect this parameter if the password is not entered before the set default is executed. If the parameter is unlocked with the password, and the module is restarted, the parameter is locked again.

**Note:** This parameter is password protected. To change its value, a valid password must first be supplied through parameter #102 (“FB Password”).

Parameter Name	'PDP ID Num Cfg'
Parameter Number	107
Modbus Address	7007h
Default Value	1810h
Range	0000h - FFFFh
Size	2 byte
Stored in NV RAM	Yes
Access	R(W)

## PROFIBUS ID Number Actual (Parameter #108)

This parameter holds the actual PROFIBUS ID number after the Anybus-IC has been initialized. Before the Anybus-IC is initialized, the value of this parameter is not defined.

Parameter Name	'PDP ID Num Act'
Parameter Number	108
Modbus Address	7008h
Default Value	-
Range	0000h - FFFFh
Size	2 bytes
Stored in NV RAM	No
Access	R

## Default Config Data Length (Parameter #109)

This parameter holds the length of the default configuration data sent to the master when a Get\_Cfg telegram is received from the master. The default configuration is entered in parameter #115 ("Default Config Data"). This register should be updated before the module is initialized in order to have effect.

Parameter Name	'Def Cfg Data Len'
Parameter Number	109
Modbus Address	7009h
Default Value	-
Range	00h - 18h
Size	1 byte
Stored in NV RAM	No
Access	R/W

## Config Data Length (Parameter #110)

This parameter holds the configuration data length when the Chk\_Cfg telegram is received from the PROFIBUS master. The data is found in parameter #116 ("Config Data"). Before the Chk\_Cfg telegram is received from the PROFIBUS master, the length of the Anybus-IC calculated configuration data are present here.

Parameter Name	'Cfg Data Len'
Parameter Number	110
Modbus Address	700Ah
Default Value	-
Range	00h - 18h
Size	1 bytes
Stored in NV RAM	No
Access	R

### User Parametrization Data Length (Parameter #111)

This parameter holds the User Parametrization Data length when the Set\_Prm telegram is received from the PROFIBUS master. The data can be found in parameter #117 (“User Parametrization Data”).

Parameter Name	'Usr Prm Data Len'
Parameter Number	111
Modbus Address	700Bh
Default Value	-
Range	00h - EDh
Size	2 bytes
Stored in NV RAM	No
Access	R

### Extended Diagnostic Length (Parameter #112)

This parameter holds the length (in bytes) of the Extended Diagnostic data entered in parameter #118 (“Extended Diagnostics”). Note that the Indication Word (see 5-11 “Indication Word”) is not included in this value.

Parameter Name	'Ext Diag Len'
Parameter Number	112
Modbus Address	700Ch
Default Value	-
Range	00h - C8h
Size	1 byte
Stored in NV RAM	No
Access	R/W

## SSA Enable (Parameter #113)

This parameter makes it possible to disable the support for the Set\_Slave\_Address telegram (SSA).

**Note:** This functionality is only implemented in firmware revision 1.14 or higher.

Parameter Name	'SSA Enable'
Parameter Number	113
Modbus Address	700Dh
Default Value	01h
Range	00h - 01h
Size	1 byte
Stored in NV RAM	Yes
Access	R/W

- **Value**

**00h:** Disable SSA support

(SSA telegrams will be rejected with the error code RS (No resource). The FBNA-bit in parameter #8 will be ignored.)

**01h:** Enable SSA support

(SSA telegrams will be accepted, and the node address will be stored in parameter #114)

## SSA Node Address (Parameter #114)

This parameter holds the node address received from the fieldbus via the Set\_Slave\_Address telegram.

**Note:** This functionality is only implemented in firmware revision 1.14 or higher.

Parameter Name	'SSA Node Address'
Parameter Number	114
Modbus Address	700Eh
Default Value	7Eh
Range	00h - 7Eh
Size	1 byte
Stored in NV RAM	Yes
Access	R

## Default Config Data (Parameter #115)

This parameter holds the default configuration data sent to the master when a Get\_Cfg telegram is received from the master. The length of the default configuration data is entered in parameter #109 (“Default Config Data Length”).

If no default configuration data is specified in this register, the module will calculate the configuration data based on the initialized I/O lengths.

This register should be updated before the module is initialized in order to have effect.

Parameter Name	'Default Config'
Parameter Number	115
Modbus Address	700Fh - 701Ah
Default Value	-
Range	00h - FFh
Size	24 bytes
Stored in NV RAM	No
Access	R/W

## Config Data (Parameter #116)

This parameter holds the configuration data when the Chk\_Cfg telegram is received from the PROFIBUS master. The length is found in parameter #110 (“Config Data Length”). Before the Chk\_Cfg telegram is received from the PROFIBUS master, the Anybus-IC calculated configuration data are present here.

Parameter Name	'Config'
Parameter Number	116
Modbus Address	701Bh - 7026h
Default Value	-
Range	00h - FFh
Size	24 bytes
Stored in NV RAM	No
Access	R

## User Parametrization Data (Parameter #117)

This parameter holds the User Parametrization Data when the Set\_Prm telegram is received from the PROFIBUS master. The length can be found in parameter #111 (“User Parametrization Data Length”). The first byte of the User Parametrization Data is reserved for the PROFIBUS ASIC and should always be left at 0 by the user.

Parameter Name	'User Param Data'
Parameter Number	117
Modbus Address	7027h - 709Dh
Default Value	-
Range	00h - FFh
Size	237 bytes
Stored in NV RAM	No
Access	R

## Extended Diagnostics (Parameter #118)

The application can send user specific diagnostics a.k.a. Extended Diagnostics to the PROFIBUS master. (See 5-1 “Extended Diagnostic Data (Slave\_Diag)” for more information).

The length of the actual Extended Diagnostic data is specified in parameter #112 (“Extended Diagnostic Length”).

Parameter Name	'Ext Diagnostics'
Parameter Number	118
Modbus Address	709Eh - 7102h
Default Value	-
Range	00h - FFh
Size	200 bytes
Stored in NV RAM	No
Access	R/W

The first word in the Extended Diagnostic data field specifies the type of diagnostic data. The data is sent when this word has been updated, which means that the actual diagnostic data must be written before this word is updated.

### Indication Word

b15	b14	b13	b12	b11	b10	b9	b8	b7	b6	b5	b4	b3	b2	b1	b0
-	-	-	-	-	-	-	-	-	-	-	-	-	OFL	STA	EXT

- **EXT**
  - 1: Extended diagnostic is indicated to the PROFIBUS master.
  - 0: Status diagnostic is indicated to the PROFIBUS master.
- **STA**
  - 1: Static diagnostic is indicated to the PROFIBUS master.
- **OFL**
  - 1: Diagnostic overflow is indicated to the PROFIBUS master.

## Firmware Revision (Parameter #119)

This parameter holds the firmware revision number.

**Note:** This parameter is password protected. To change its value, a valid password must first be supplied through parameter #102 (“FB Password”).

Parameter Name	'Firmware Revision'
Parameter Number	119
Modbus Address	7103h
Default Value	(firmware revision of Anybus module, set at manufacturing)
Range	0000h - FFFFh
Size	2 bytes
Stored in NV RAM	No
Access	R(W)

## Serial Number (Parameter #120)

This parameter holds a unique 32-bit serial number.

**Note:** This parameter is password protected. To change its value, a valid password must first be supplied through parameter #102 (“FB Password”).

Parameter Name	'Serial Number'
Parameter Number	120
Modbus Address	7104h
Default Value	(serial number of Anybus module, set at manufacturing)
Range	00000000h - FFFFFFFFh
Size	4 bytes
Stored in NV RAM	No
Access	R(W)

# Fieldbus Specific Initialization

## General Information

By default, the application does not need to acknowledge any telegrams from the PROFIBUS master; all handshaking etc. is handled automatically by the module.

Optionally, the module can be initialized in Fieldbus Specific Mode, offering greater control over User Parametrization Data and Configuration Data. To start the module in this mode, the Fieldbus Specific Initialization option in parameter #1 (“Module Mode”) is used.

## Initialization State Machine

The fieldbus specific initialization process can be described by a state diagram as follows:

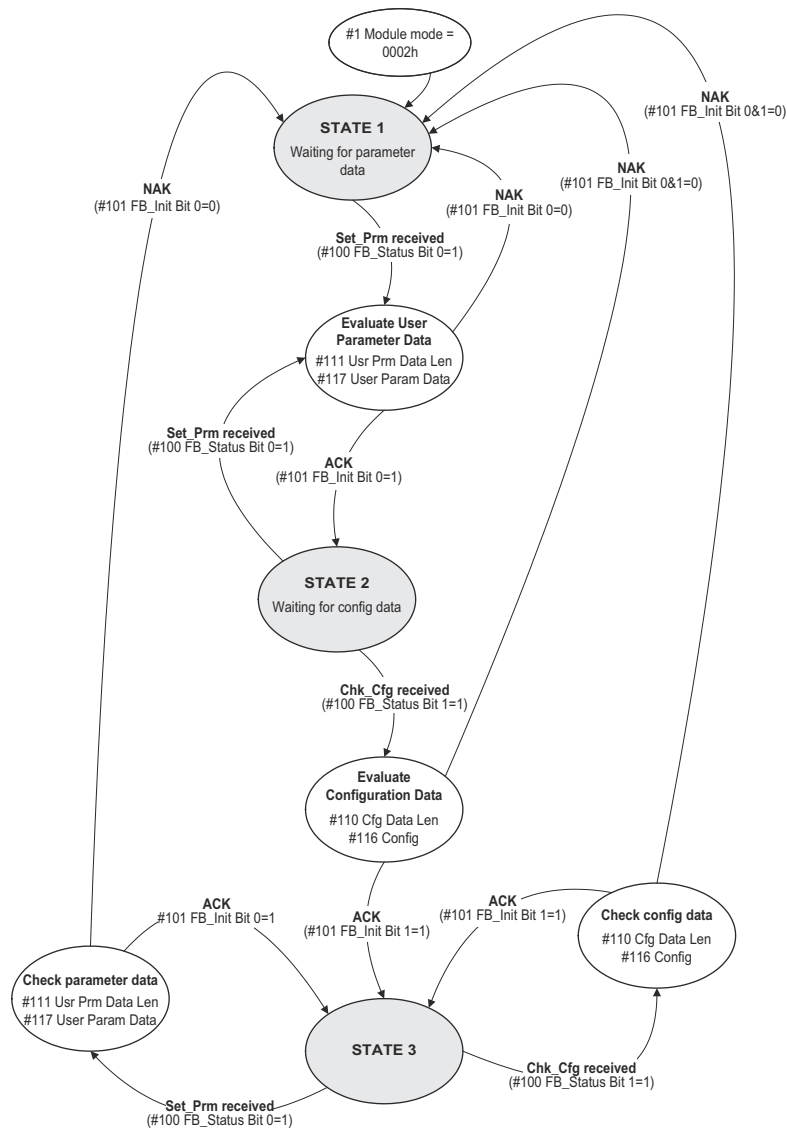

## STATE 1 (Initial state)

The module awaits the Parametrization Data from the PROFIBUS master. When received (indicated by bit #0 of parameter #100 ('Fieldbus Status')), the application must evaluate the User Parametrization Data by checking parameters #111 ('Usr Prm Data Len') and #117 ('User Param Data').

- If the User Parametrization Data is ok, the application shall accept the telegram by setting bit 0 of parameter #101 ('FB Init'). The application shall then enter STATE 2.
- If the User Parametrization Data is not ok, the application shall reject the telegram by clearing bit 0 of parameter #101 ('FB Init'). The application shall then remain in STATE 1.

## STATE 2

The module awaits Configuration Data from the PROFIBUS master. When received (indicated by bit #1 of parameter #100 ('Fieldbus Status')), the application must evaluate the Configuration Data by checking parameters #110 ('Cfg Data Len') and #116 ('Config Data').

- If the Configuration Data is ok, the application shall accept the telegram by setting bit 1 of parameter #101 ('FB Init'). The application shall then enter STATE 3.
- If the Configuration Data is not ok, the application shall reject the telegram by clearing bits 0 and 1 of parameter #101 ('FB Init'). The application shall then return to STATE 1 and expect a new initialization sequence.

## STATE 3

This state handles all PROFIBUS telegrams received after the initialization is finished and is also the 'normal' runtime state. The bus is online and exchanging I/O data in this state.

- If a 'SET\_PRM'-telegram is received, the application must evaluate the User Parametrization Data. If the User Parametrization Data is ok, the application shall remain in STATE 3.  
If the User Parametrization Data is not ok, the application shall return to STATE 1 and expect a new initialization sequence.
- If a 'CHK\_CFG'-telegram is received, the application must evaluate the Configuration Data. If the Configuration Data is ok, the application shall remain in STATE 3.  
If the Configuration Data is not ok, the application shall return to STATE 1 and expect a new initialization sequence.

**Note:** If the fieldbus goes off line and then back to online (e.g. if the fieldbus connector is temporarily disconnected and then re-connected again), the initialization sequence must restart from STATE 1 again.

**Note:** If both the 'SET\_PRM'- and 'CHK\_CFG'-telegram is received, and the application accepts both telegrams, it is possible to acknowledge both simultaneously by writing 03h to parameter #101 ('FB Init'). This is only allowed when both telegrams shall be acknowledged. If any of the telegrams shall be rejected, it must be made one at a time in the order described in the flowchart on the previous page.

**Note:** If the CHK\_CFG telegram shall be rejected, both bits (#0 and #1) of parameter #101 ('FB Init') must be cleared.

# Technical Specification

## Electrical Specification

### Protective Earth (PE) Requirements

See 5-1 “Fieldbus Specific Parameters”.

### Power Supply

#### Supply Voltage

The module requires a regulated  $5V \pm 5\%$  DC power supply as specified in the Anybus-IC Design Guide.

#### Power Consumption

The maximum power consumption is 150mA.

## Environmental Specification

- **Temperature**

Test performed according to IEC-68-2-1 and IEC 68-2-2.

Operating: -40 to +85 °C (-40 to 185°F)

Storage: -40 to +85 °C (-40 to 185°F)

- **Humidity**

The product is designed for a relative humidity of 5 to 95% non-condensing.

Test performed according to IEC 68-2-30.

## EMC Compliance (CE)

EMC pre-compliance testing has been conducted according to the following standards:

- **Emission:** EN 50 081-2:1993

Tested per EN 55011:1998, class A, radiated

- **Immunity:** EN 61000-6-2: 1999

Tested per EN 61000-4-2:1995

EN 61000-4-3:1996

EN 61000-4-4:1995

EN 61000-4-5:1995

EN 61000-4-6:1996

