

CASE STUDY: TRANSPORT

Solution:	Gateway solutions
Country:	China
Company:	Guangzhou Metro
Summary:	Anybus Communicators enable communication between different devices in Guangzhou Metro's surveillance system and the ControlNet network.



The effects

- ✓ 210,000 I/O points connected.
- ✓ No programming of PLC communication protocol conversions required.
- ✓ Project finished one month ahead of time.

"The Anybus Serial Gateway does not require programming and can be configured to use a uniform method to access sub-systems; thereby, saving us a great deal of time in the project implementation stage."

Zhao Feng, HollySys' project manager of the Guangzhou Metro Line 5 project.

Rockwell Automation and HMS to Provide Intelligent Solutions for the Guangzhou Metro Line 5 BAS system

Automated technology promotes modernization of rail operations management.

In light of Guangzhou's current economic development, continuously increasing population, and ever more congested traffic conditions, its regional economic integration is merely a blink away. Metropolitan rail systems provide numerous advantages such as large capacity, high efficiency, and low pollution emissions. These systems have become tools germane to solving transportation issues inherent to large Chinese cities. Using the original rail network as a foundation, construction of Guangzhou Metro Line 5 began in 2005 - thereby reshaping the metro network. Line 5 spans east to west and runs through Guangzhou City. In total the line stretches approximately 40 kilometers and includes 24 stations - the metro system plays a crucial role in the transportation network of Guangzhou City. In conformity to Guangzhou City's general strategic plan of "Into the East, unify with the West, attain harmony", Metro Line 5 adheres to rail line connection conditions set with the cities of Foshan, Dongguan and Shenzhen. Initial daily capacity supports up to 50 million passengers.

Guangzhou Metro Line 5 utilizes advanced integrated monitoring systems; the use of such a system provides a more powerful information platform for operations. Passengers can thus expect more comprehensive service quality in regards to stability, safety, and efficiency. The BAS system is a major sub-system of the comprehensive monitoring system.

This subsystem monitors automated management systems – such as station and tunnel ventilation, air conditioning, water supply and drainage, and elevator and escalator operation – to create a comfortable traveling environment by ensuring that all equipment maintains peak operating conditions. In case of emergency such as the occurrence of a fire, the system controls and coordinates the electrical and mechanical equipment to prevent smoke from spreading freely, thereby ensuring passenger safety.

Challenge

The Guangzhou Metro Line 5 system has numerous points with large amounts of data. The comprehensive monitoring system has a total of about 210,000 I/O points. The entire project

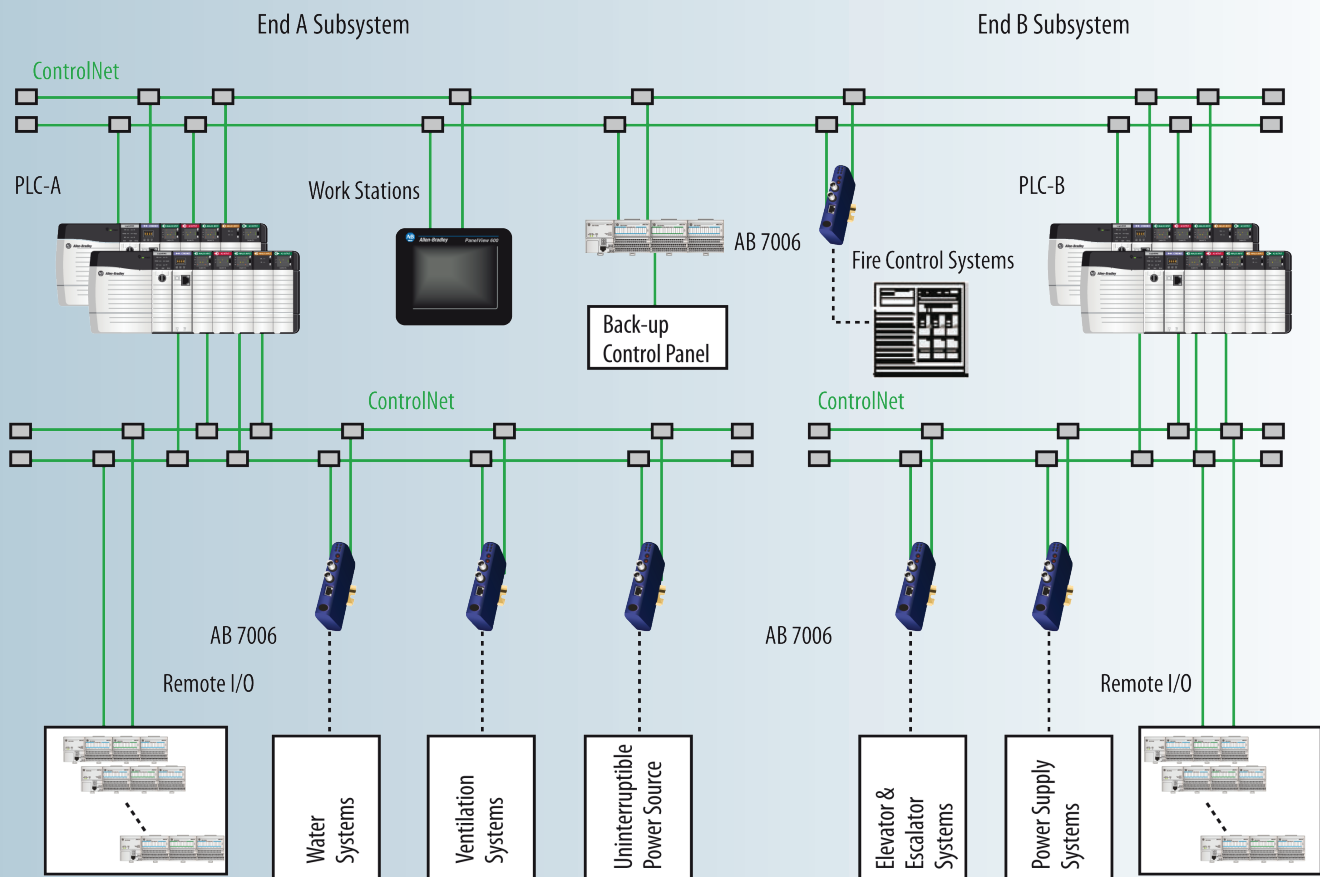

was forecasted to contain 280,000 points, of which 70,000 points were allocated to the BAS system. System integration required a great deal of work. Deadlines were tight, and 24 stations were to be simultaneously opened - never before in the country had so many stations been opened at one time.

The automated operating platform of Guangzhou Metro Line 5 requires sharing of resources and information, as well as fluid interoperation between sub-systems. A substantial amount of sub-systems support different protocols and a variety of devices need to access the BAS system; thereby, increasing the requirements for information transmission.

“Our goal is to create a highly secure, highly reliable, and highly automated integrated environmental equipment monitoring system to provide passengers a safe and comfortable traveling environment. Faced with this challenge, we need not only choose a powerful automated system and experienced integration provider, but also select a stable and reliable network communication solution that allows all kinds of equipment accessibility to the BAS system”, spoken early in the project by Mr. Feng Xiaoqing at Guangzhou Metro Construction Headquarters.

Solution

HollySys Automation Technologies, a Beijing-based firm, implemented the Guangzhou Metro Line 5 BAS system. The firm boasts rich

experience in application of such systems; it is competent in both R&D and project implementation. HollySys has accumulated years of experience as it has participated in the construction of several rail transit lines in mainland China.

The Rockwell Automation system is widely used in the rail transport field. The central segment of the Metro Line 5 BAS system uses ControlLogix Redundancy Controllers from the Rockwell Automation Integrated Architecture platform. The ControlLogix system provides discrete, drives, motion, process, and safety control together with outstanding performance. FAS communication programming is quick and simple in all three control modes: manual control mode, automated thermodynamic control mode, and time control mode.

In connection with real-time control requirements, the network control layer uses the ControlNet redundant media solution to ensure system security and stability. For data acquisition and control, remote equipment goes through a distributed FLEX I/O that shares the ControlLogix platform.

The BAS system requires communication with varied sub-systems (ex. EPS, UPS, FAS, coolers, etc.). Most of these devices use the RS-485 interface and support the Modbus Anybus ControlNet Serial Gateway (AB7006) Guangzhou Metro Line 5 Control Center protocol or a custom protocol.

According to HollySys, how these devices access the PLC System is an integral part of the project. Understanding the Rockwell Automation Encompass Product Partner Program, HollySys sought out Encompass partner HMS Industrial Networks, a Swedish firm, to discuss accessibility solutions for the BAS system and its sub-systems.

HMS Industrial Networks' Anybus gateway solutions are used around the world to enable connectivity for third-party network components. Considering that the sub-systems of Guangzhou Metro Line 5 support unique protocols, HMS Industrial Networks recommended adopting the AB7006 Serial Gateway. The gateway utilized a rail-mounted DIN with a redundant ControlNet network as the standard ControlNet adapter; therefore, the gateway could be installed in the equipment control stack or the main control stack. Since equipment in the Metro stations are positioned far apart, the gateway program avoided data retrieval problems associated with overstretched RS-485 cables.

The serial gateway supports a wide range of serial protocols and user-defined protocols. Programming PLC communication protocol conversions are not required; thus saving a great deal of time in debugging communication. Use of AB7006 custom protocols and FAS system communication smoothly solved BAS and FAS interface issues; a process believed to be one of the most difficult in debugging.

Results

The BAS system was completed one month before Guangzhou Metro Line 5 was successfully commissioned in December 2009. "This project had a tight schedule, including arduous tasks, and was technically difficult; the multiple interfaces of the BAS system brought about many difficulties. Successful completion of the



project is a testament to the high quality and professionalism of the team. Debugging of the BAS system was smooth. The project was completed on schedule and the Metro is safe," said an evaluation from the Guangzhou Metro Construction Headquarters.

Mr. Zhao Feng, HollySys' project manager of the Guangzhou Metro Line 5 project, stated the following when officially opening the system to operation: "the Anybus Serial Gateway does not require programming and can be configured to use a uniform method to access sub-systems; thereby, saving us a great deal of time in the project implementation stage. Each of the sub-systems goes through the Anybus Serial Gateway to access the BAS system. This allowed monitoring and linkage between mechanical/electrical equipment and systems. In all, the Anybus Serial Gateway improved the monitoring capabilities of electrical and mechanical equipment on the subway - improving safety and stability. It created a safe and comfortable traveling environment for passengers."

In light of its successful experience with Guangzhou Metro Line 5, HollySys used the Rockwell Automation and HMS Industrial Network solution in tenders for future projects. The firm has recently won bids for Beijing Yizhuang Subway Line, Shenzhen Metro Line 2, Shenzhen Metro Line 1 Extension Project, and Beijing Subway Line 8 Phase II.

Learn more on www.anybus.com or www.gzmtr.com/en/



Anybus Communicator Gateways

Anybus Communicator can connect almost any automation device with a serial communication interface to fieldbus and industrial Ethernet networks. The Communicator performs an intelligent conversion between the serial protocol of the automation device and the chosen industrial network.

HMS Industrial Networks develops and manufactures state-of-the-art hardware and software for industrial communication. Products are marketed within the categories Embedded Solutions, Gateways and Remote Management. HMS was founded in 1988, is headquartered in Halmstad, Sweden and is listed on the NASDAQ OMX Nordic Exchange in Stockholm, ISIN-code: SE0002136242.

Anybus[®] is a registered trademark of HMS Industrial Networks AB, Sweden, USA, Germany and other countries. Other marks and words belong to their respective companies. All other product or service names mentioned in this document are trademarks of their respective companies.

Part No: MMA6011 - © HMS Industrial Networks - All rights reserved - HMS reserves the right to make modifications without prior notice.